

Bluetooth Based Smart Automation System Using Android

Ms. Swati M. Patil^{1*}, Prof. Poonam V. Gaikwad²

¹ Department of Computer Science & Engineering, Karmayogi Engg. College, Shelve, Pandharpur.

² Department of Computer Science & Engineering, Sveri's COEP, Pandharpur.

*Corresponding author

doi: <https://doi.org/10.21467/proceedings.118.45>

ABSTRACT

The word automation is automatic control of operating devices with minimal or reduced human efforts. Influence of wireless technology is growing day by day. In today's world, wireless technology doing significant role in the automation. It means automation makes technology free from human interruption. Home automation is one of the technology emerging these days. To make it more effective and efficient, cost is reduced by low cost communication technology like Bluetooth, Wi-Fi. Bluetooth is wireless technology to use in home automation. It is no operational cost technique, common in use and working in range up to 100 meters [2]. Bluetooth which is mainly used for data exchange, add new features to smartphones. With help of android application we are able to connect and control household appliances and provide security to handicapped, old people.

The idea of paper is to control home appliances like lights, fan. It also provides home security and emergency alerts to be activated. It is possible to save energy by auto off lights at night time. Smoke detector can detect smoke or gas leak condition, causing alerts to user on their smartphone. Our home automation works smartly by providing increased quality of life, and comforts to users.

Keywords: Bluetooth Wireless Technology, Smartphones, Home Automation System, Arduino Uno, Android, Bluetooth Module, Temperature Sensor, Smoke Detection.

1 Introduction

Automation is a technique, method, or system of operating or controlling a process by electronic devices with reducing human involvement to a minimum. The fundamental of building an automation system for an office or home is increasing day-by-day with numerous benefits. Industrialist and researchers are working to build efficient and affordability automatic systems to monitor and control different machines like lights, fans, AC based on the requirement. Automation makes not only an efficient but also an economical use of the electricity and water and reduces much of the wastage. Automation is another important application of wireless technologies like Bluetooth. It is the monitoring of the energy consumption and the Controlling the environment in buildings, schools, offices and museums by using different types of sensors that control lights, temperature. To make it more operative and efficient, cost is reduced by low cost communication technology like Bluetooth.

Bluetooth is nice technology to use in home automation [2]. This technology allows to the users instantaneous connections of voice and information between several devices in real time. The way of transmission used assures protection against interferences and safety in the sending of information in arrange up to 100 meters. Building upon this theme; we propose a home automation system based on Bluetooth technology available in Android smartphones.

Implemented design are considering few issues for smart home automation. They are: Easy setup, Easy to control and monitor, Low cost and efficient communication. Our paper presents Bluetooth based centrally controlled home automation system using smartphones and Arduino Uno board. Such a system will enable users to have control over lights, fan in his home with Bluetooth. All that the user needs is an Android



smartphone, which is present in almost everybody's hand nowadays, and a control circuit. The control circuit consists of an Arduino Uno microcontroller, which processes the user commands and controls the switching of devices. The connection between the microcontroller and the smartphone is established via Bluetooth, a widespread wireless technology used for sharing data. This application also focuses on smoke detection and temperature sensing by providing security to application against unauthorized user.

2 System Design

Our Home automation system uses an Android based Bluetooth enabled phone for its application and the Arduino Uno as the microcontroller. The key components of this system are:

- i. Arduino Uno
- ii. Bluetooth module
- iii. Android based phone

i) Arduino Uno:

The Arduino Uno is a microcontroller board based on the ATmega328p [9]. It is simple, inexpensive, open source prototyping platform extensible to hardware and software. It has 14 digital input/output pins (of which 6 can be used as PWM outputs), 6 analog inputs, a 16 MHz ceramic resonator, a USB connection, a power jack, and a reset button. It contains everything needed to support the microcontroller. We either need to connect it to a computer using a USB cable or power it with an AC-to-DC adapter. The Arduino circuit acts as an interface between the software part and the hardware part of the project.



Fig 1. Arduino Uno Board

ii) Bluetooth Module

Bluetooth is a wireless technology standard for exchanging data over short distances [11] (using short-wavelength UHF radio waves in the ISM band from 2.4 to 2.485 GHz) from fixed and mobile devices, and building personal area networks (PANs). The Bluetooth module being used allows us to transmit and receive signals. It receives the text from the Android phone and transmits it to the serial port of the Arduino Uno. The Bluetooth module being used here is the HC-05 module, shown in fig. 2. It is an easy to use Bluetooth SPP (Serial Port Protocol) module, designed for transparent wireless serial connection setup. The Bluetooth module HC-05 is a master/slave module [12]. By default the factory setting is slave. The Role of the module (Master or Slave) can be configured only by at commands. The slave modules cannot initiate a connection to another Bluetooth device, but can accept connections. Master module can initiate a connection to other devices.



Fig 2. Bluetooth HC-05 Module

iii) Android based phone

Android is software stack for mobile devices that includes an O.S, middleware and key applications. Android O.S is based on Linux and applications are made in java [10] like a language running on virtual machine called 'Dalvik' created by Google [1]. For this automation system and security we are using open source android platform .Our Android application consisting of controlling device list as lights, fans according to rooms. First user has to start application, for safety purpose username and password is given for authorized user. If user is authorized he will be asked for making Bluetooth ON. After that he will be having list of available devices in range for serial connection. Once he connects to HC-05 he will be navigated to main screen which is consisting of list of devices of that he wants to control as make it on or off, display current temperature, set time for auto off devices at night time.

As our system is based on Bluetooth technology, as shown in fig.3, system involves wireless connection into Smartphone and Bluetooth module HC-05. Bluetooth Module and all appliances are connected with Arduino Uno Board directly with help of wires and breadboard. This system works on client-server model, here Bluetooth in Smartphone is act as server while HC-05 acts as client.

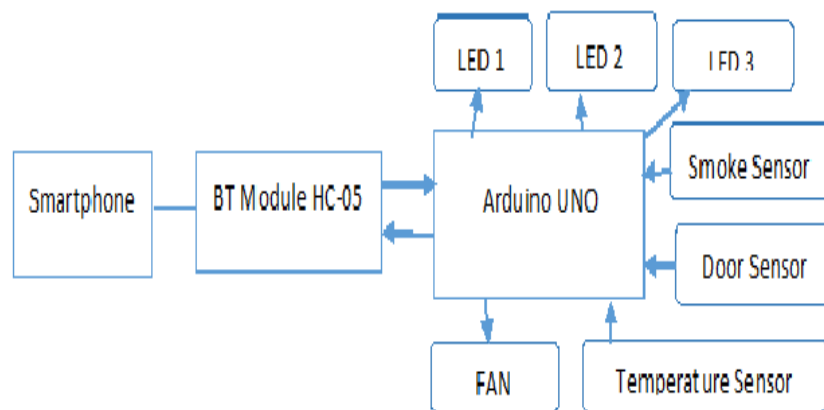

Fig 3. Block diagram of smart automation system using Bluetooth

3 Application

Smart Automation System having following applications:

- Control home appliances like turn ON/OFF lights in every room and Turn off fan, turn it on LOW/HIGH speed within Bluetooth range from android Smartphone application.
- In terms of lighting control system, it is easy to AUTO OFF lights at night time by setting time for saving wastage of energy in residential passage.

- Smoke detector can detect smoke or gas leakage condition causing alert notification highlighted on user's smartphone.
- Able to know current temperature in room in degree Celsius.
- When user is in home or out of home activation of door security, when door opened by thief, buzzer started continues alarm tone for alert notification.

4 Conclusions

Our paper has objective to develop smart home automation with help of Arduino and Bluetooth wireless technology. Our purpose to develop such application is not only for common man but will be boon for elderly and disabled. System allow user to monitor and control household appliances like lights, fan. It involves auto off lights at night by setting time. We can also able to see current temperature. It secures home by alerting people when smoke detected or gas is leaked. In terms of security, doors and windows are secured by setting alarm in case of any kind of thief movement. Our project is feasible because the cost is very less as compared to other systems and easy to handle, freely available.

References

- [1] Deepali Javale, Mhd.Mohsin, Shreerang Nandanwar, Mayur Shingate, "Home Automation and Security System Using Android ADK", International journal of Electronics and Computer Technology, Vol 3, Issue 2(March 2013).
- [2] Sudhir Kumar, Monica Deswal, "Smart Home System", 2013 International conference on Advances in Computing and Communication.
- [3] R.Piyare, M.Tazil "Bluetooth Based Home Automation System Using Cell Phone", 2011 IEEE 15th International Symposium on Consumer Electronics
- [4] N. Sriskanthan and Tan, Karande. "Bluetooth Based Home Automation System". Journal of Microprocessors and Microsystems, Vol. 26, pp.281-289, 2002.
- [5] Al-Ali, Member, IEEE & M. AL-Rousan, "Java-Based Home Automation System R." IEEE Transactions on Consumer Electronics, Vol. 50, No. 2, MAY 2004.
- [6] Muhammad Izhar Ramli, Mohd Helmy Abd Wahab, Nabihah, "TOWARDS SMART HOME: CONTROL ELECTRICAL DEVICES ONLINE", Normabihah Ahmad International Conference on Science and Technology: Application in Industry and Education (2006).
- [7] E. Yavuz, B. Hasan, I. Serkan and K. Duygu. "Safe and Secure PIC Based Remote Control Application for Intelligent Home". International Journal of Computer Science and Network Security, Vol. 7, No. 5, May 2007.
- [8] H. Kanma, N. Wakabayashi, R. Kanazawa, H. Ito, "Home Appliance Control System over Bluetooth with a Cellular Phone," IEEE Transactions on Consumer Electronics, vol. 49 , no. 4, pp.1049-1053, Nov. 2003.